

MACROECONOMIC FACTORS INFLUENCE THE DISTRIBUTION OF MSME FINANCING IN INDONESIAN ISLAMIC BANKS

Mariatul Fitri^a, Annisa Masruri Zaimsyah^{b*}

^{a,b} Islamic Banking Program, Sekolah Tinggi Agama Islam Hubbulwathan Duri

*Corresponding Author: annisamasruri@gmail.com

ABSTRACT

This study examines macroeconomic factors affecting MSME financing in Indonesian Islamic banks from 2014 to 2021. These factors include inflation, BI rate and exchange rate. The methodology of this study is a quantitative method using the OLS approach. The data used in this study is monthly data from 2014 to 2021. Data was collected from Central Bank and OJK publications. This study found that macroeconomic conditions also affect how MSME financing is channeled in Islamic banks, so inflation and exchange rate partially, but BI Rate does not affect the distribution of MSME financing. This is because Islamic banks do not use an attractive interest rate system but a profit-sharing system. The findings of this study have significant consequences for decision makers, Islamic banks, and market participants. Islamic banks should work more to provide financing for MSMEs. Islamic banks should use innovation and creativity to develop and market new products in MSME financing. Due to its narrow focus on MSME financing in Islamic banks, this research has several limitations including that this research only focuses on macroeconomic factors, many other factors can affect MSME financing such as internal bank factors. Further research can examine the impact of Islamic banking financing on MSME development.

Keywords: Macroeconomics, Islamic Bank, Financing, MSME, Indonesia

1. Introduction

In the economy, the banking sector is the heart of a country. The role of banking significantly affects economic activity. So it can be said that the progress of a bank and a benchmark for the progress of a country. However, the banking industry is a sector that is vulnerable to risk because this sector deals with the level of trust in the return of funds in the future. Many parties predict that the economy in Indonesia, including banking, will collapse.

Islamic banking is a bank system that operates under current Sharia law. Islamic banks are financial institutions that follow Sharia law yet common reason to other traditional banks. As a consequence, these banks need not participate in usury or even other economic transactions that contradict Shariah principles (Alharb, 2017). Depending on the state of the country's finances, every country, including Indonesia, experiences ups and downs in the expansion of Islamic banking. The

collaboration between Islamic banks and regional micro-entrepreneurs is a clear illustration of the sharia-based economic system that can adversely affect the lower-class economic sector (Abas, 2017). This shows the importance of product innovation from Islamic banking to develop and strengthen small entrepreneurs (MSMEs).

Microenterprises are widely recognized as engines of economic growth, and the sector has influenced the financial and economic development decisions of economists and policymakers worldwide (Al Balushi et al., 2019; Charmondusit et al., 2012). In developing countries in Asia, micro, small and medium-sized enterprises (MSMEs) have contributed to the region's economic growth. (1) the number of enterprises, (2) job creation, (3) production and value-added, (4) gross product or gross domestic product (GDP), (5) the number of enterprises founded by women entrepreneurs; and (6) the area of the industrial market (Tambunan, 2011) so that it is necessary to increase to help the development of MSMEs both in terms of capital by providing financing, training or others.

The condition of macro variables greatly influences the investment decisions taken by investors. When monetary conditions, especially macroeconomic indicators, show a downward trend, profits from the business sector will generally decline. Then, economic conditions expected to improve will be a positive sentiment that impacts increasing profits from the business sector. Economic conditions will affect market conditions, whereas market conditions will also affect the profits earned by investors. In addition to affecting investors, economic conditions will also affect the performance of the banking sector (Z. Ibrahim et al., 2021). One indicator of banking sector performance is Financing Growth. Investment instruments in Islamic banking are also closely related to financing growth. Increasing financing quality will increase the margin and profit-sharing income from Islamic banking. One of the financing priorities and dominant financing in Islamic banking is MSME sector financing. SMEs are widely recognized as engines of economic growth, and economists and policymakers around the world have made the SME sector important in their financial and economic development decisions (Al Balushi et al., 2019)

In financing, many factors affect the financing from within and outside the bank. Banks, including Islamic banks, play a major role as intermediaries in optimally distributing surplus funds to those in need (Sukmana and Febriyati, 2016). One way to do this is by improving SME lending and strengthening the role of national banks as intermediaries (Meydianawathi, 2007). As lending is the main function of Islamic banks, more attention must be given to lending because it can improve the economic performance of a country. Islamic banks have a major contributor to real sector funding. Islamic Bank financing in the MSME sector at the end of 2021 reached 71.06 trillion or a portion of 8.88% of all financing provided by Islamic Banks to the business sector. MSME financing has a portion of 18.21% of total Islamic banking financing (Otoritas Jasa Keuangan, 2022)

Islamic banks significantly aid in financing the real sector market. Islamic banks primarily serve as intermediaries, therefore given that lending can boost economic performance, it deserves more attention (Ahmad & Halim, 2014). Research by Ibrahim and Sufian (2014) said funding from Islamic banks is affected by macroeconomic factors, namely inflation and the BI rate. Nahar, S. & Sarker (2016) Contradicting these results, it is discovered that the exchange rate adversely affects the capacity of Islamic banks to raise capital. Therefore, this study focuses on the external factors that influence funding for micro, small, and medium-sized businesses from Islamic commercial banks as indicated by inflation, the BI Rate, and the exchange rate for the Rupiah.

With variables that affect the allocation of funds to microfinance, such as MSMEs (Utami, 2018). Macroeconomic variables will affect the number of third-party funds from Islamic banks. The profit

level taken from this financing will also affect MSMEs because the higher the profit was taken on the funding provided, the more reluctant people will be to use profit-sharing services at Islamic banks. After all, the costs do not equal the benefits that MSMEs will obtain. In addition, macroeconomic factors also influence the bank's decision to channel its funds.

Research conducted by Ibrahim and Sukmana (2011), an investigation into the effects of macroeconomic factors on Islamic finance in Malaysia, found that while the real sector was unaffected by macroeconomic factors, interest rates and stock market movements had a small impact on Islamic finance.. Ali (2015), a study was done on the effect of macroeconomic and banking factors on financing expansion of the banking system in Albania. Credit expansion in Albanian banks is influenced by macroeconomic and banking factors. Therefore, increase in finance is favorably influenced by the GDP, inflation, and capital adequacy ratio. Although interest rates, bad debts, and bank size have little impact on the expansion of bank funding. Amelia & Hardini (2017) Inflation and currency rate variables were discovered in Islamic people's financing banks in Indonesia, and they have a major impact on bank financing funding. In Alexandria's research (2015), the internal and external factors influencing financing in Islamic banks are CAR, ROA, SIZE, GDP and Inflation. It is proven that ROA has a significant effect on funding (Alexandri & Santoso, 2015). In their research, Nahar, S. and Sarker (2016) found that the Exchange Rate negatively affects the ability to provide financing from Islamic banks.

This study uses the most recent data from 2014 to 2021. Moreover, this study focuses only on macroeconomic variables. By paying attention to the factors that affect fundraising, this research helps Islamic banks maximize their business of channeling funds through fundraising. Small and micro-entrepreneurs can take loans from Islamic banks to develop their business with proper financial management and avoid fraud.

2. Literature Review

Effect of Inflation on MSME Financing

Inflation is the constant increase in the price of domestic goods and services (Mankiw, 2018). Inflation can mean a decrease in the value of money in goods and services, as the increase in prices of goods and services leads to a reduction of the value of money in the economy. Consumer pricing index (CPI) increases for certain products and services are often what drive inflation (BPS, 2022). Several factors cause inflation. In particular, supply pressure arises when the price level of trading partners rises and government intervention in the price of certain commodities. And since aggregate demand flows faster than production flows, inflation is demand-driven. Inflation can be measured using the Consumer Price Index (CPI). This is the rate of change in the average consumer price of goods and services, which can change at specific intervals or over several years (Data.worldbank.org, 2022). CPI is estimated as the proportional change in the price of single consumer goods and services with constant quantity and characteristics from period to period (Mankiw, 2018).

As measured by the Consumer Price Index, inflation reflects the annual rate of change in the cost of the average consumer to purchase a basket of goods and services at regular intervals, be amended or changed annually (Datacatalog.worldbank.org). A rise in the price of just one or two goods cannot be called inflation except when the rise extends (or causes a price rise) to other goods. The opposite of Inflation is called deflation (www.bi.go.id, 2022). Inflation can also be understood as an economic condition characterized by a sharp rise in prices that affects a decline in purchasing power. Due to rising public consumption and low long-term savings, this is frequently followed by a drop in investments and

savings. In the financial sector, inflation is rampant and out of control, and banks could resist efforts to raise public cash. This is due to the fact that strong inflation lowers the actual interest rate. People's willingness to save less as a result, which slows capital growth for community banks.

Inflation generally hurts the economy (Hesniati et al., 2022). As a result of inflation, people experience an increase as the prices of goods and services continue to rise. The implication is that people with more funds will buy goods and services. As a result, the country will be vulnerable to all the chaos caused. Inflation in this study is measured by inflation proxies based on CPI using bps.go.id data. Ali (2015), Amelia and Hardini (2017) and Alexandri & Santoso (2015) found inflation affects the distribution of financing in Islamic Banks. The effect of Inflation on MSME financing is that if inflation is higher, it will cause a decrease in MSME financing distribution.

Hypothesis 1: Inflation positively affects the distribution of MSME financing.

Effect of BI RATE on MSME Financing Disbursement

The BI rate is a benchmark interest rate that reflects Bank Indonesia's stance on monetary policy. Public announcements are made as well. After then, a number of other economic indicators were taken into account to determine whether the BI rate increased or decreased. such as macroeconomics, inflation, and potential monetary policy (amarbank.co.id, 2022). The Bank Indonesia (BI) rate, also known as the SBI interest rate or BI rate, is used to adjust weighting during money control activities and serves as a signaling instrument for the bank. Utilized as a resource for The monthly interest rate of SBI from OPT bids, or the interest rate for goods with modified liquidity, is comparable to the BI rate. The interest charge is a yearly charge. Percentage of the loan, from the loan. It is calculated by dividing the annual interest payment by the loan balance. The cost of a loan is another way to define interest rate. The percentage of the principal amount per unit of time is how interest rates are calculated (Hesniati et al., 2022).

The increase in the BI rate has caused Sharia Commercial Banks to increase their financing offers, including to the MSME sector because Sharia Commercial Banks will get a more significant profit share. Because Sharia Commercial Banks will receive little profit sharing, a fall in the BI rate results in a decrease in MSME borrowing. This is in line with Putra and Rustariyuni (2015), which proves that the BI rate positively affects working capital loans disbursed by BPRs in Bali Province. Also, Husaeni et al., (2021); and Sari et al., (2012), prove that the BI rate positively affects lending. Thus the BI Rate serves as a signal of monetary policy, and it can be concluded that Indonesia's monetary policy asked for the increase, decrease or stay off the BI Rate.

Hypothesis 2: BI Rate has a positive effect on the distribution of MSME financing

The Effect of Exchange Rates on MSME Financing

A currency exchange rate or exchange rate is the price of a foreign currency in the local currency. It can also be said that the price in local currency is relative to the foreign currency. For example, the Rupiah to US Dollar (USD) exchange rate can also be interpreted as the price of 1 US Dollar (USD) in Rupiah (Rp) or the price of 1 Rupiah to 1 US Dollar. An exchange rate or rate is the price of one country's currency to another country's currency. Exchange rates may be measured or expressed in other currencies. Exchange rates are also called value comparisons. When an exchange takes place between two currencies, the values or prices of the two currencies are compared. Fluctuations in the value of the Rupiah affect the smooth running of business. This is because when the exchange rate is weaker than the foreign exchange rate, the production costs increase when producers use imported raw materials. It

also affects export costs. Exchange rates, therefore, affect the allocation of funds. Nahar, S. and Sarker, (2016), in their research, found that the Exchange Rate negatively affects the ability to provide financing from Islamic banks.

Hypothesis 3: Foreign Exchange Rate positively affects the distribution of MSME financing.

3. Method

The variables BI Rate, Inflation, and Exchange Rate have a data window of January 2014 through December 2021. Data from the Central Bureau of Statistics show that Indonesia's MSMEs experienced very rapid growth in 2014. There are 69 records for each variable in the study's overall data set. According to Cohen (2007), the larger the sample, the better the research, but there is a minimum number that researchers must take, namely 30 samples. Processing data is done with Eviews 9. The Indonesian Islamic commercial banks are the subject of this study. The study focused on the Islamic Banking Statistics financial statements released by the Financial Services Authority and the Bank of Indonesia (OJK). The Central Bureau of Statistics also contributed information (BPS). The ordinary least squares (OLS) approach is used in the multilinear analysis method to measure the parameters. The benefit of utilizing this OLS approach is that, when all assumptions are true, it is the coefficient method that is most suited for forecasting the future.

The OLS equation estimation in this study can be formulated as follows:

$$Y = \alpha + \beta_1 X_1 + \beta_2 X_2 + \beta_3 X_3 + e. \quad (1)$$

Description

- Y = MSME Financing Distribution Variable (MSME)
- A = Coefficient
- $\beta_1 X_1$ = Coefficient of Inflation Effect
- $\beta_2 X_2$ = BI Rate Influence Coefficient
- $\beta_3 X_3$ = Coefficient of Exchange Rate Effect
- e = error

This study require a conventional hypothesis test first before performing multiple linear regression. Normality, multicollinearity, heteroscedasticity, and autocorrelation are the first tests run. The following hypotheses are included in the model:

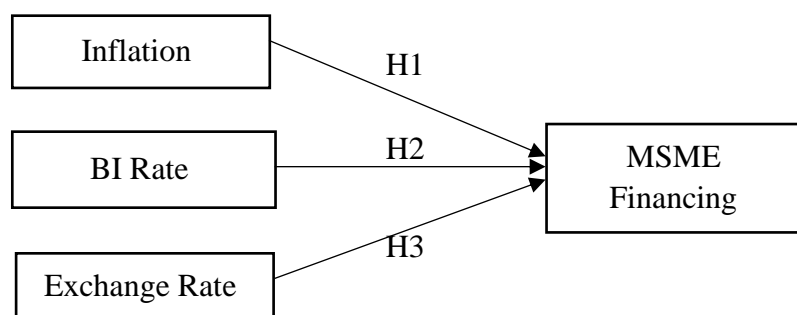

Figure 1
The Research Model

4. Result and Discussion

Results

This section describes the test results and subsequent analysis. We performed traditional assumption tests for normality, heteroscedasticity, multicollinearity, and autocorrelation in this study. Table 1 shows the average standard deviation for each variable examined. Also, the order of discussion begins with inflation, BI rates, and exchange rates.

Table 1
Statistical Description of Variables

	N	Mean	Maximum	Minimum	St. Deviasi
MSMEs	96	47541.4	109506	35662	14174.92
INFLATION	96	3.74	8.36	1.32	1.84
BI RATE	96	6.05	7.75	4.25	3.13
EX RATE	96	13679	16367	11404	910.37

Source: Data Processed (2022)

Based on Table 1, the average funding variable (Y) provided by Islamic banks to MSMEs is 47541.4, with a maximum value of 109506, a minimum value of 35662, and a standard deviation value of 14174.92.

Table 2
Results of Hypothesis Testing

Variable	Coefficient	t	Prob
C	75586.73	10.13831	0.0000
INFLATION	2095.612	3.612700	0.0047
BI RATE	68.62899	0.489939	0.6347
EX RATE	-1.326796	-2.417606	0.0362

Source: Data Processed (2022)

Table 2 shows that five variables are at the significance level of 0.05. Inflation and exchange rate variables related to MSME funding in Islamic banking. However, exchange rates adversely affect the distribution of Islamic bank loans to MSMEs.

Table 3.
Model Feasibility Test Results

Sum of Squares	R-Squared	Adjusted R-Squared	F	Prob
3818463	0.719560	0.635429	8.552769	0.004109

Source: Data Processed (2022)

The F-test or joint test results are obtained from Table 3. Since the F value is 8.552769 at probability level 0.004109, the variables affecting MSME funding have a positive effect at the same time. Table 3 also shows that the R-squared coefficient of determination is 0.719560 or 71.9%. This means that the factor affecting MSME funding is 71.9%. In contrast, 28.1% were influenced by other variables not examined in this study.

Discussion

Effect of Inflation on MSME Financing

The results obtained in Table 2 show that the inflation variable has statistically significant results with significance values of $0.0047 < 0.0047 < 0.05$ Shaw. The t-value of the inflation variable is 3.612700, but we can say that H1 is accepted. This study's results align with Amelia and Hardini, (2017) research, this states that inflation affects the distribution of funds. This indicates that rising inflation will increase his allocation of MSME funds to Islamic banks. These results are also supported by research by Ali (2015), which found that inflation affects credit in banks. Uncontrolled high inflation can interfere with banking efforts in channelling funds to the public, including to MSMEs. A high inflation rate will cause interest rates to fall. A fall in actual interest rates can affect two things: a reduction in the public's desire to save and a relatively low real interest rate compared to actual interest rates abroad, which can result in an influx of foreign capital.

Who discovered that inflation affects bank lending. High unbridled inflation could hamper banks' efforts to fund the masses, including MSMEs. If inflation is high, interest rates will fall. A fall in real interest rates, he said, has two effects. The demographic willingness to save and the relatively low real interest rates compared to those abroad may lead to an outflow of foreign capital.

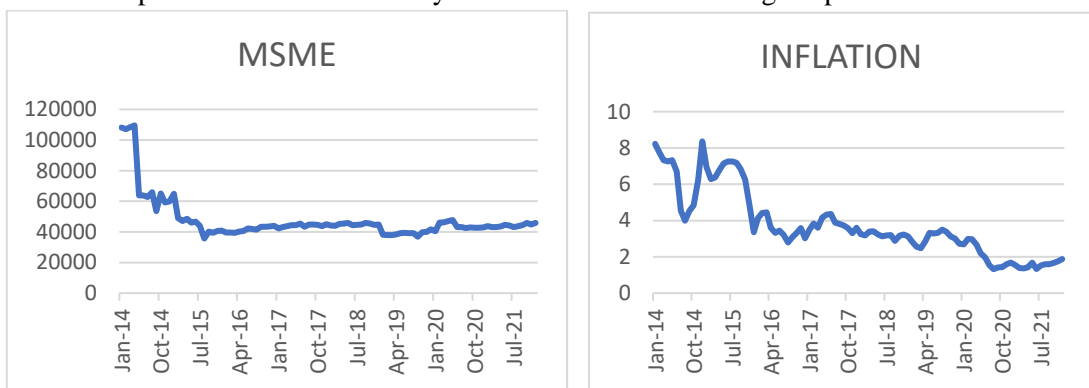

Figure 2.

Development Chart of Inflation and MSME Financing 2014-2021

Source: Data Processed (2022)

Effect of BI Rate on MSME Financing

Results Obtained in Table 2 The results obtained in Table 2 show that the BI rate variable has a statistically insignificant result with a significant value of $0.6347 > 0.05$. The variable BI rate shows results that do not affect the distribution of Islamic bank loans to MSMEs. Therefore, H-2 is rejected due to lack of significance between BI rate and allocation of MSME funds in Islamic banks. This indicates that this study does not support the findings Husaeni et al., (2021); Putra and Rustariyuni (2015) and Sari et al (2012). The lack of impact of the BI rate on the allocation of funds to MSMEs may be due to the fact that Islamic banks do not use interest rates and apply the profit-sharing or profit-loss-sharing principle.

From Figure 3, the BI rate graph does not change significantly from 2014 to 2021, which is inconsistent with MSME funding allocations.

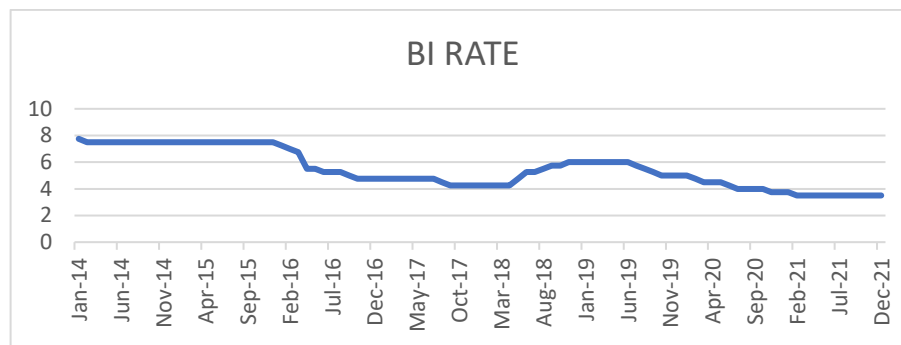

Figure 3.
BI Rate Development Chart 2014-2021

Source: Data Processed (2022)

Effect of Exchange Rate on MSME Financing

The exchange rate variable shows negative results in Table 2. That is, the exchange rate significance value of 0.0036 is less than the significance level of 5%. At the same time, the t-value for the exchange rate is -2.41760. Exchange rate variables impair the distribution of MSME funds. So we can say that H3 is accepted. These results are consistent with the work done by Nahar and Sarker (2016), When the exchange rate of a country's currency increases, net imports increase (more imports than exports). This could lead to higher consumption and lower production, impacting lower lending volumes at traditional and Islamic banks. Figure 4 shows that the exchange rate movement graph does not match his MSME lending growth. The exchange rate is relatively inverse to the MSME fund allocation.

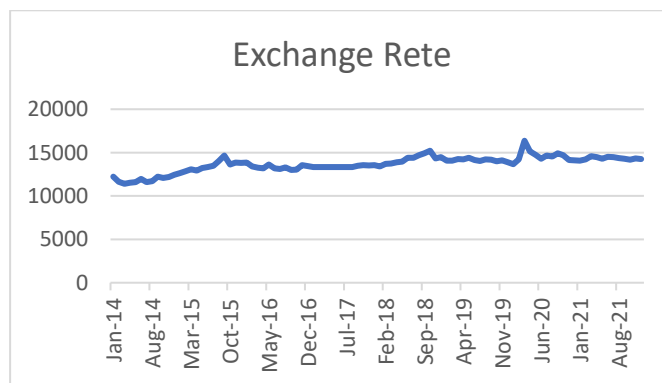

Figure 4.
Exchange Rate Development Chart 2014-2021

Source: Data Processed (2022)

5. Conclusion

Macroeconomic considerations also have an impact on Indonesia's Islamic banks' volume of MSME loans. The macroeconomic environment will change, which will have an indirect impact on the structure of Islamic banks and the financing function of Islamic banks as an intermediary, particularly in the MSME sector. For business stakeholders, Islamic banks, and policymakers, this conclusion has significant ramifications. Islamic banks need to make a bigger effort to lend to micro, small, and medium-sized businesses. When creating and presenting new products connected to financing to

MSMEs, Islamic banks must be particularly inventive and creative. Due to its narrow focus on MSME financing in Islamic banks, this study has some limitations. However, this research can be further improved by considering taking into account other conventional bank financings, in addition to MSMEs and other macroeconomic indicators. Further research can examine the impact of financing provided by Islamic banks on developing MSMEs.

6. Reference

- Abas, S. (2017). The Role Of Sharia Banking In Strengthening The Micro, Small, And Medium Enterprises In North Maluku, Indonesia. *International Journal of Scientific & Technology Research*, 6(10). www.ijstr.org
- Ahmad, A. A., & Halim, M. A. A. (2014). The concept of hedging in Islamic financial transactions. *Asian Social Science*, 10(8), 42–49. <https://doi.org/10.5539/ass.v10n8p42>
- Al Balushi, Y., Locke, S., & Boulanouar, Z. (2019). Determinants of the decision to adopt Islamic finance: evidence from Oman. *ISRA International Journal of Islamic Finance*, 11(1), 6–26. <https://doi.org/10.1108/IJIF-02-2018-0020>
- Alexandri, M. B., & Santoso, T. I. (2015). Non Performing Loan: Impact of Internal and External Factor (Evidence in Indonesia). *International Journal of Humanities and Social Science Invention*, 4(1), 87–91.
- Alharb, A. T. (2017). International Journal of Islamic and Middle Eastern Finance and Management Determinants of Islamic banks' profitability : international evidence. *International Journal of Islamic and Middle Eastern Finance and Management*. <https://doi.org/10.1108/IMEFM-12-2015-0161>
- Ali, S. (2015). Importance and Implications of CPEC in South Asia: The Indian Factor. *Journal of Indian Studies*, 1(1), 16. http://pu.edu.pk/images/journal/indianStudies/PDF/2_v1_1_15.pdf
- amarbank.co.id. (2022). *No Title*.
- Amelia, E., & Hardini, E. F. (2017). Determinant of Mudharabah Financing: A Study at Indonesian Islamic Rural Banking. *Etikonomi*, 16(1), 43–52. <https://doi.org/10.15408/etk.v16i1.4638>
- BPS. (2022). *Badan Pusat Statistik*. <https://www.bps.go.id>
- Charmondusit, S., Bhaktikul, K., Arunlertaree, C., Wisawapipat, W., Rattanapan, C., & Charmondusit, K. (2012). Problem Based Training Program on Industrial Ecology and Environment for the Sustainability Management of Industry. *Procedia - Social and Behavioral Sciences*, 40, 31–36. <https://doi.org/10.1016/j.sbspro.2012.03.157>
- Cohen, L. (2007). *Research Methods in Education (6th Ed)*. Routledge.
- Data.worldbank.org. (2022). *Consumer Price Index*. data.worldbank.org
- Hesniati, Koo, F., Fernando, Winardy, J., & Chuandra, W. F. (2022). The Impact of BI Rate, Exchange Rate, and Inflation on Broad Money in Indonesia. 2005–2003 ,(8.5.2017)4 ,٧٧٨7.
- Husaeni, U. A., Zakiah, S., & Faisal, F. (2021). Determinants of Micro and Small Business Financing In Sharia Commercial Banks In Indonesia. *Journal Ilmiah Ekonomi Islam*, 7(03), 1499–1504.
- Ibrahim, M. H., & Sufian, F. (2014). A structural VAR analysis of Islamic financing in Malaysia. *Studies in Economics and Finance*, 31(4), 371–386. <https://doi.org/10.1108/SEF-05-2012-0060>
- Ibrahim, M. H., & Sukmana, R. (2011). Dynamics of Islamic financing in Malaysia: Causality and innovation accounting. *Journal of Asia-Pacific Business*, 12(1), 4–19. <https://doi.org/10.1080/10599231.2011.539446>
- Ibrahim, Z., Effendi, N., Budiono, B., & Kurniawan, R. (2021). Determinants of profit and loss sharing financing in Indonesia. *Journal of Islamic Marketing*. <https://doi.org/10.1108/JIMA-01-2020-0015>
- Mankiw, M. G. (2018). *Pengantar Ekonomi Makro (Ketujuh)*. Salemba Empat.
- Meydianawathi, L. . (2007). The Analysis of Bank Credit Bergaining Behaviour on SME Sector in Indonesia. *Economy Study Bulletin*, 12.



- Nahar, S. & Sarker, N. (2016). Are Macroeconomic Factors Substantially Influential for Islamic Bank Financing? Cross-Country Evidence. *Journal of Business and Management*, 18(6), 20–27.
- Otoritas Jasa Keuangan. (2022). *Statistik Perbankan Syariah*. Ojk.Go.Id. www.ojk.go.id/
- Putra, I. G., & Rustariyuni, S. D. (2015). Pengaruh DPK, BI Rate, Dan NPL Terhadap Penyaluran Kredit Modal Kerja Pada BPR Di Provinsi Bali Tahun 2009-2014. *E-Jurnal Ekonomi Pembangunan Universitas Udayana*.
- Sari, G. N., Yang, F., Mempengaruhi, F. Y., Kredit, P., Umum, B., Ekonomi, F., & Pembangunan, J. E. (2012). Faktor-Faktor Yang Mempengaruhi Penyaluran Kredit Bank Umum Di Indonesia (PERIODE 2008.1 – 2012.2). *Jurnal EMBA*, 1(3), 931–941.
- Sukmana, R., & Febriyati, N. A. (2016). Islamic banks vs conventional banks in Indonesia: An analysis on financial performances. *Jurnal Pengurusan*, 47, 81–90.
- Tambunan, T. T. H. (2011). Development of Micro , Small and Medium Enterprises and Their Constraints : A Story from Indonesia. *Gajah Mada International Journal of Business*, 13(1), 21–43.
- Utami, U. R. (2018). The Effect of Bank's Internal Factors Towards Micro Financing in Islamic Commercial Bank at Indonesia. *Journal of Islamic Economic Laws*, 1(1), 78–98. <https://doi.org/10.23917/jisel.v1i1.6327>
- www.bi.go.id. (2022). *Bank Indonesia*. www.bi.go.id