

Design of Automatic Transfer Switch on A Renewable Energy Hybrid Grid System at PT Lentera Bumi Nusantara

Muhammad Abdillah^{1*}, Tri Mutia¹, Teguh Aryo Nugroho¹, Nita Indriani Pertiwi¹

¹*Department of Electrical Engineering, Universitas Pertamina, Jakarta, Indonesia*

Abstract—Currently, the transition between renewable energy sources and PLN sources at PT LBN is done manually by conducting scheduled monitoring. However, this method is less efficient and depends on the readiness of the operator. Therefore, in this Final Project, the design and construction of an Automatic Transfer Switch (ATS) on a renewable energy hybrid grid system at PT LBN is carried out where the source switching is based on the battery voltage value so as to shorten the source switching time while protecting the battery from undervoltage conditions. The main components used in the construction of this ATS system are contactors, relays, relay control circuits, ESP32, LCD 1604, and voltage divider circuits. The result of this final project is an ATS system that has a voltage sensor error of 0 - 1.187%. The monitoring of the ATS system was also successfully accessed from near and remotely in real time. The ATS that was built has a faster source switching time than the manual method, which is 21.6 ms - 40.1 ms.

Keywords—ATS, hybrid grid, IoT, PT Lentera Bumi,

I. INTRODUCTION

Continuity in the flow of electricity is the hope of every user, as well as at PT Lentera Bumi Nusantara (PT LBN). This company requires electrical energy to support social business activities in the fields of energy, food, and transfer of knowledge/technology to the younger generation. PT LBN utilizes renewable energy in the form of wind and solar energy as the main source. However, the renewable energy system has a drawback, namely the fluctuating source. Thus, the electrical energy produced is not always able to supply the load. To overcome this condition, an additional source of electrical energy from the State Electricity Company (PLN) was added as a backup source. These three power sources are connected into a hybrid grid system.

To perform source switching between inverter sources (PLTB and PLTS) and PLN sources, a transfer switch is used, which is a device that connects the load with the selected source. The use of transfer switches in the electrical system aims to ensure that the load is always electrified continuously. Thus, damage to electronic equipment due to electrical power instability can be avoided. Transfer switch can work manually

and automatically. Manual transfer switches operate based on human actions and responses directly. And the automatic transfer switch works automatically with the help of sensors and actuators as a substitute for the senses.

At this time, the process of switching sources at PT LBN is done manually by conducting scheduled monitoring of the battery voltage value. This is done to prevent the use of batteries in undervoltage conditions which can shorten battery life [1]. Measurements were made using a multimeter between 07.00 – 22.00 with an interval of 3 hours. When the battery voltage is <24.5 Volts the source is switched to the PLN power source and will be switched back to the inverter source when the battery voltage is >25.5 Volts. In addition to carrying out scheduled monitoring, the transfer of electrical energy sources is also carried out based on the conditions that occur. When the source of electrical energy is suddenly cut off (the power goes out), then immediately check the battery voltage and the condition of the switch to find out the energy source connected to the load.

Both methods are considered less efficient because the time it takes to measure the battery voltage to pull/push the lever on the manual transfer switch is relatively long, which is around 3 minutes. Operators need to check in the Battery Station (BS) room which is located separately from the location of the operator's usual activities. The operator's delay in checking results in the disruption of the continuity of the electrical energy source [2] and causes a decrease in battery quality.

Therefore, an Automatic Transfer Switch (ATS) was designed, which is a device that can control the switching of electrical energy sources automatically. ATS is designed to work based on the value of the battery voltage while displaying information on the value of the battery voltage that can be accessed using a Wi-Fi WLAN network. The application of IoT in this ATS system aims to shorten the operator's time to find out the value of the battery voltage and the source being used. By applying ATS to the electrical system, the source switching process will be more efficient [3].

II. FUNDAMENTAL THEORY

A. Hybrid Grid

A hybrid grid in the electrical system is the use of two or more generating systems. In PT LBN, two types of renewable

Corresponding Author:
Muhammad Abdillah
Department of Electrical Engineering, Universitas Pertamina

Jl. Teuku Nyak Arief, Simprug, Kebayoran Lama, Jakarta 12220. Indonesia
Email: m.abdillah@universitaspertamina.ac.id

energy sources are used, namely PLTB and PLTS, and one source of PLN. The energy generated from the PLTB and PLTS systems is stored in the battery. Then it is connected to an inverter which functions to convert DC electricity from the battery into AC electricity so that it can be used to power electronic devices which are generally AC loads.

B. Automatic Transfer Switch

An automatic Transfer Switch (ATS) is a circuit system that can switch the energy supply from one source to another automatically so that the load is always electrified. The discontinuity of electrical energy can damage electronic equipment and will also cause discomfort for users of electrical energy

C. Modul ESP32

The ESP32 module has a clock frequency between 80MHz - 240MHz so the data processing speed is faster than other microcontrollers such as the Arduino Uno which only has an 8-bit processor and a clock frequency of 16MHz.

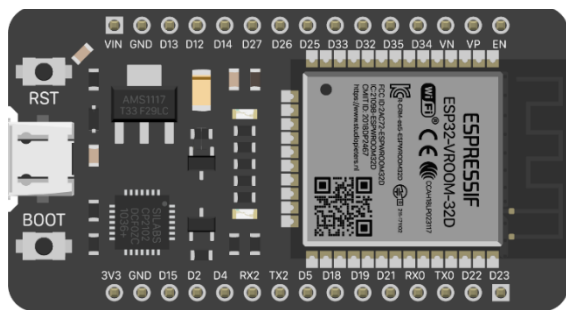

Figure 1 ESP32-VROOM-32D Modul Module

The operating voltage of the ESP32 is 2.7 V – 3.6 V so it is more energy efficient than other microcontrollers. The number of ESP32 ADC pins is also more with a higher resolution of 12 bits (arduino has 6 ADC pins with a resolution of 10 bits) so that the accuracy of sensor readings is higher.

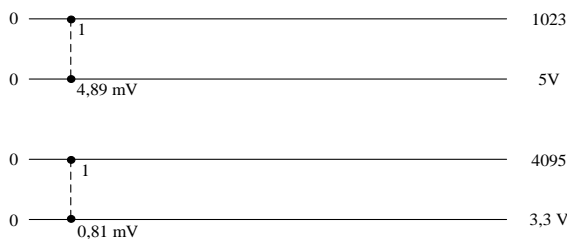

Figure 2 Comparison of Accuracy between Arduino Uno and ESP32 . ADC Pins

The Arduino Uno ADC pin has a resolution of 10 bits with a maximum voltage of 5V, the sensor reading range is 0-1023. While the ESP32 ADC pin has a 12-bit resolution with a maximum voltage of 3.3 V, the sensor reading range is 0-4095. Based on Figure 2, it is known that on the Arduino Uno ADC pin with a resolution of 10 bits, 1 bit is equal to 4.89 mV. While on the ESP32 ADC pin which has a resolution of 12 bits, 1 bit is equal to 0.81 mV. So it can be concluded that the higher the resolution of the ADC pin, the more accurate the sensor reading will be.

D. Relay

The relay is used to close or open the switch contacts automatically. In electromechanical relay (EMR), the relay works on the principle of electromagnetism. When an electric current is applied to a wire, a magnetic field is created around the wire. The phenomenon of the emergence of a magnetic field due to an electric current is used to open and close the switch contacts.

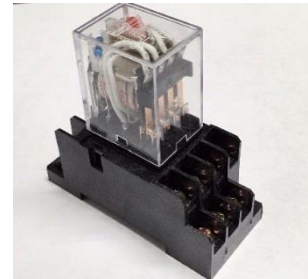

Figure 3 Relay

In general, the relay has two parts, namely coil, and contact. The coil consists of a coil of wire connected to a power source and the contact is a switch that is controlled based on the presence of a current connection to the coil. When the coil is energized, an electromagnetic force will arise which will attract the armature so that the contacts will move. At first, the contacts are connected in Normally Closed (NC) mode, then become connected in Normally Opened (NO) mode. The relay used in this final project is a 12VDC relay. The following are the specifications of the relay used.

Table 1 Relay Specification

Model	MY4N with indicator light
Voltage rating coil	12 Vdc
Current rating coil	75 mA
Mac Voltage Contact	24 Vdc/220 Vac
Maximum Contact current	3 A
Operating time	20 ms max
Recovery time	20 ms max

E. Relay Control Circuits

In order for the relay to be controlled using a digital signal sent by the ESP32 digital pin, a relay control circuit is required. The 12V relay control circuit is shown in Figure 4.

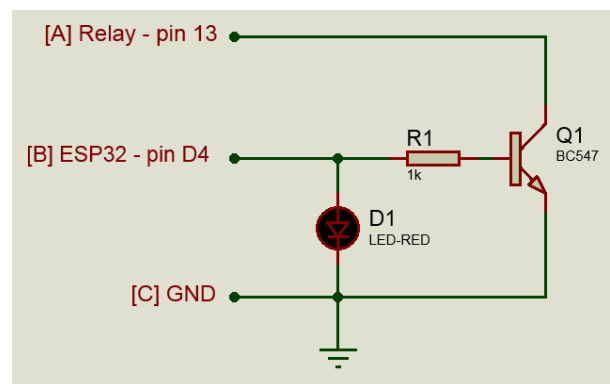

Figure 4 Relay control circuit

F. Contactor

According to NEMA (National Electrical Manufacturers Association), a magnetic contactor is a device that moves magnetically repeatedly to connect and disconnect electrical circuits [4]. The working principle of a magnetic contactor is the same as a relay, namely controlling the condition of the contact by adjusting the input voltage on the coil. Contactors are designed to connect and disconnect electrical circuits at a higher power level than the relay.

The contactor consists of a main contact, auxiliary contact, and contactor coil. The main contact consists of 3 pairs of NO contacts with numbering using the numbers 1-2, 3-4, and 5-6. The main contact is designed to carry current with a relatively large value such as the load current in the electrical system so that by construction the main contact has a wider size with a thick structure. While the auxiliary contacts consist of NO contacts and NC contacts which are designed to carry relatively small electric currents such as currents for control circuits so that the construction is narrower and thinner. Then the contactor coil is a part that is built from wire coils and has electromagnetic properties which is given the symbol A1-A2. When the contactor coil is energized, there will be magnetic properties in the coil which change the contactor contact which was initially in the NO condition to NC or vice versa.

G. Voltage Sensor

The voltage sensor is designed using the voltage divider principle according to Kirchoff's II Law which states that in a closed circuit the potential difference must be equal to zero. The following is a series of voltage sensors used.

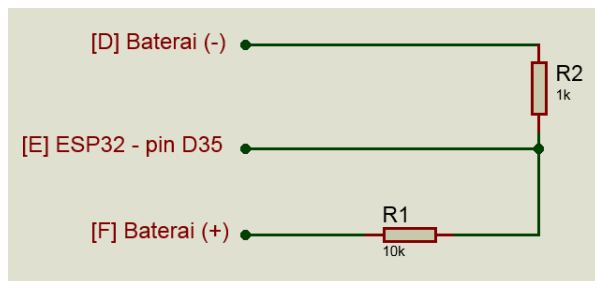

Figure 5 Voltage Divider Circuit

The maximum voltage that this voltage sensor can measure is 35V. This determination is carried out by considering the maximum voltage data that has been achieved by the battery when it is full-charged, which is 30 V. After determining the maximum voltage that can be measured by the sensor, then the resistance values R_1 and R_2 are calculated using the following equation.

$$V_{i \max} ADC = \frac{R_2}{R_1 + R_2} \times V_{\max} \text{ baterai} \quad (1)$$

$$3,3 \text{ Volt} = \frac{R_2}{R_1 + R_2} \times 35 \text{ Volt} \quad (2)$$

$$R_1 = 9,6R_2 \approx 10R_2 \quad (3)$$

From the above calculation, it is known that the ratio of R_1 to R_2 is 10: 1. When the measured voltage is 35V, the voltage that enters the ADC pin of the microcontroller is about 3.3V. The voltage sensor should only be used in the 0-35V voltage

range so that the maximum voltage that enters the microcontroller ADC pin is not more than 3.3 V. If the microcontroller ADC pin is given a voltage of more than 3.3V it will cause damage to the microcontroller components.

H. Liquid Cristal Display

LCD serves to display numeric characters, letters or symbols according to the user's wishes. The 1604 LCD is an LCD that has 16 columns and 4 rows. LCD 1604 has 16 pins that will be connected to the microcontroller pins. To reduce the use of many pins, an I2C LCD module is used so that the number of pins used is 4 pins, namely VCC, GND, SLA and SCL.

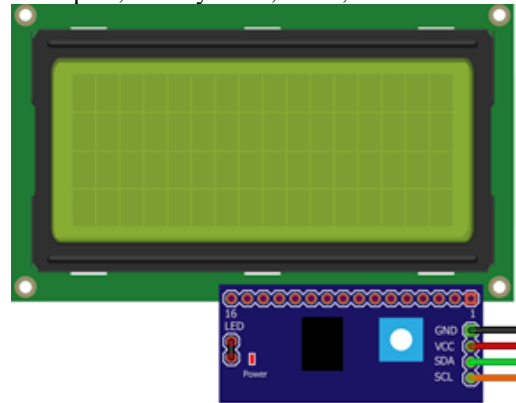

Figure 6 LCD with I2C . module

I. Internet of Things

Internet of Things (IoT) is a technology that uses the internet network to make devices interact with each other [5]. IoT provides advantages in terms of easy, practical and efficient use. One of the uses of IoT is in monitoring and control. Monitoring and data collection of equipment performance and energy use can be accessed in real-time at the time and place the user wants with the condition of an adequate internet network.

III. METHOD

A. Procedure of Designing ATS

The ATS workflow in this Final Project begins with connecting the two sources on the ATS with the load, namely the inverter source and the PLN source. Also performed initiation on the voltage sensor. In the initial condition, the main contact of the inverter contactor is disconnected and the main contact of the PLN contactor is connected. Then the battery voltage value is read by the voltage sensor. When the measured battery voltage is < 24.5 V, the inverter contactor contact will remain disconnected and the PLN contactor contact will remain connected. However, if the measured battery voltage is > 24.5 V then there will be two choices, namely a voltage > 25.5 V or < 25.5 V. If the battery voltage is > 25.5 V, the inverter contactor contact will be connected and the PLN contactor contact will be disconnected. Meanwhile, if the measured voltage is < 25.5 V, there will be two options again, namely checking the current active source is the inverter or PLN. If the last active source is PLN, the inverter contactor contact will remain disconnected and the PLN contactor contact will remain connected. However, if the last active source is an inverter, the inverter contactor contact will be connected and

the PLN contactor contact will be disconnected. The LCD and the web page will display the measured voltage value and the information on the power source used is the inverter source/PLN source.

The battery voltage value is used as an indicator to switch sources with the aim of preventing the use of the battery in undervoltage conditions which can shorten battery life [1]. Batteries should not be used when they are empty, but are limited to >60% of the total battery capacity. The battery capacity information can be indicated by the battery voltage value. When the battery is empty, the battery voltage is at the minimum level. Meanwhile, when the battery is full, the battery voltage is at its maximum level. Based on the battery datasheet, the battery voltage level ranges from 21.8 – 28.8 V. Then with some considerations, PT LBN technicians set the minimum allowable battery usage limit at 24.5 V.

B. Design Systems

The specifications of the ATS to be designed are as follows.

Table 2 Specifications of Automatic Transfer Switch

Parameter	Value
Voltage Rating	220 Vac
Maximum Current	25 A
Switch time	< 1 second
Operating Voltage	2.7-3.6 V
Dimensions	30x22x10 cm

Voltage rating is the working voltage of the source that can be delivered by ATS and the maximum current is the maximum current that can be passed by ATS. This depends on the specifications of the contactor and the specifications of the source used. While the transition time is the time required by the system from detecting the voltage value to responding to changes in the source which are influenced by the specifications of the microcontroller, relay and contactor used. The operating voltage is the voltage required to activate the ATS based on the operating voltage of the microcontroller used.

C. Systems Process

Electrical energy converted by solar panels and wind turbines is connected to the charge controller so that the voltage that enters the battery becomes stable and has the same voltage level, which is 24 VDC. Then the battery is connected to an inverter so that DC electricity can be converted into AC electricity. The voltage sensor is connected to the battery to determine the value of the battery voltage so that the condition of the battery capacity is known. Then the reading results are sent to the ESP32 microcontroller via the ADC pin for data processing. The data that has been processed by the ESP32 is then sent to the LCD and web page and is used to set relay contacts. The relay is connected to an interlock circuit composed of two contactors, with the condition that both sources (inverter source and PLN source) are connected. Thus, by using the processed ESP32 data sent to the relay control circuit, the relay can set the interlock circuit and connect the load to only one source.

IV. RESULTS AND DISCUSSION

This test aims to determine the performance of the tool with the design that has been made. The test begins by connecting a voltage of 24-26 V to the voltage sensor as a representation of the battery when charging from undervoltage to rating. Then connect a voltage of 26-24 V to the voltage sensor as a simulation of the battery when it experiences discharge from the rating condition to undervoltage.



Figure 7 Front view of ATS when battery voltage < 24, 5 Volt

When the ESP32 microcontroller is activated, the voltage sensor will immediately measure the battery voltage and display the measurement results on the LCD screen and send it to a web page. Figure 7 shows the condition when the measured battery voltage is <24.5 Volts. On the LCD screen, the battery voltage value is 24.45 V and on the fourth line there is the words "SOURCE PLN". Then simultaneously the yellow PLN source indicator light will light up indicating that the source connected to the load is the PLN source.

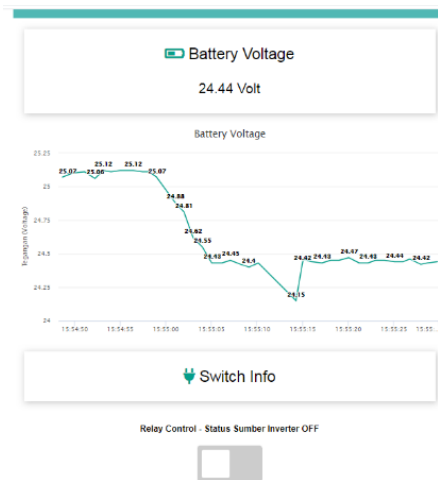

Figure 8 Web page display when battery voltage < 24, 5 Volt

The web page displays the value of the battery voltage measurement in the form of numbers and graphs as well as information on the inverter source in the OFF condition as shown in Figure 8. It can be seen in the figure that the battery voltage is 24.44 Volts and the inverter source condition is OFF.

Then when the voltage slowly rises to > 25.5 Volts, the LCD will again display the new battery voltage measurement value and the active source is the inverter source with the words "SOURCE INVERTER" on the fourth line of the LCD screen and the indicator light for the inverter lights up as shown in Figure 16.



Figure 9 Front view of ATS when battery voltage > 25.5 Volt

In Figure 9 it can be seen that when the measured battery voltage is > 25.5 Volts, which is 25.66 Volts, the active source information contained in the fourth line changes to "SOURCE INVERTER". And at the same time the green inverter source indicator light will be active. With the indicator light on, the source connected to the load is the inverter source.

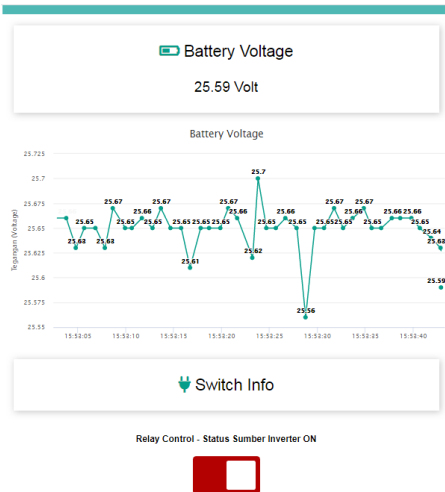

Figure 10 Web page display when battery voltage > 25.5 Volt

The web page will automatically provide the latest information on the condition of the ATS system. Figure 17 shows the value of the battery voltage measurement, which is 25.59 V accompanied by the graph below. Then at the end, information is displayed that the inverter source is in the ON condition.



Figure 11 Front view of the panel when the battery voltage is 24.5-25.5 Volts with undervoltage conditions towards rating

As for when the measured voltage is between 24.5-25.5 Volts with undervoltage conditions towards the rating, the LCD will display the value of the battery voltage measurement and the active source is the PLN source with the words "PLN SOURCE" on the fourth line of the LCD screen and the indicator light for PLN lights up as shown in Figure 11. In the figure it is known that the measured battery voltage is 24.97 Volts, and the PLN indicator light is on.

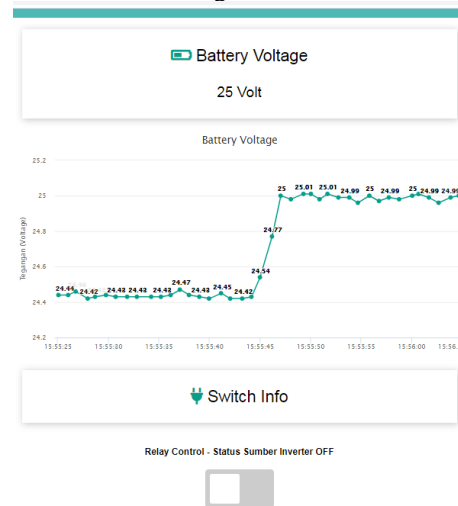

Figure 12 Web page display when the battery voltage is 24.5-25.5 Volts in undervoltage conditions towards rating

Seen from the picture above, the battery voltage has increased from 24.42 Volts to 25 Volts. And the active source is the PLN source which is marked with the status of the inverter source OFF.



Figure 13 Front view of the panel when the battery voltage is 24.5-25.5 Volts with the rating condition going to undervoltage

Meanwhile, when the measured voltage is between 24.5-25.5 Volts with the rating condition towards undervoltage, the LCD will display the measured battery voltage value and the active source is the inverter source which is marked with the words "SOURCE INVERTER" on the last line of the LCD screen. Then the inverter indicator light will light up indicating the source used is the inverter source as shown in Figure 20.

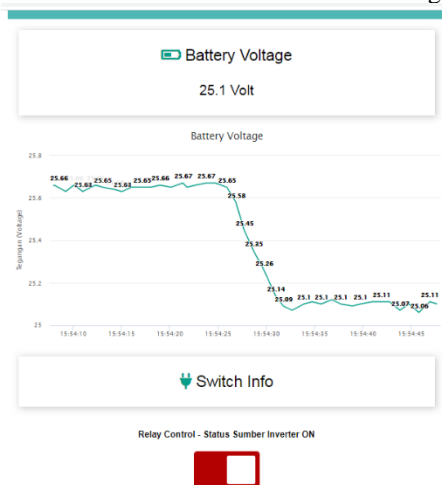

Figure 21 Web page display when the battery voltage is 24.5-25.5 Volts in the rating condition towards undervoltage

The picture above shows a graph of battery voltage against time. The graph has a negative slope indicating that the battery voltage has decreased from 26.67 Volts to 25.08 Volts. Because the measured battery voltage is still > 24.5 Volts, the active source is the inverter source which is informed by the words "Source Inverter ON" and the switch shifts to the right.

Based on the tests that have been carried out, it is known that the ATS system works according to the design that has been carried out. The ATS design results have met the design, namely ATS (Automatic Transfer Switch) which works based on the battery voltage value. Then the voltage value information and the type of source used can be displayed on the LCD screen and the web page that has been created. The web page can be accessed via a smartphone/PC connected to the same WLAN Wi-Fi network used by the ESP32 microcontroller module to

send data. The voltage sensor has an error of 0 - 1.187% compared to a multimeter. The designed ATS can also perform source switching automatically with a switching time of 21.6 ms - 40.1 ms, which means this switching time is faster than the manual method.

V. CONCLUSIONS

Based on the design, development/implementation, testing and analysis of the ATS system in this Final Project, it can be concluded that the ATS system on the renewable energy hybrid grid of PT Lentera Bumi Nusantara with control based on battery voltage was successfully built with a voltage sensor error of 0-1.187%. Then the Monitoring of the ATS system in the form of information on voltage values and active sources has been successfully accessed from a short distance via the LCD and remotely via a smartphone/PC in real-time. And the built ATS can work faster than the manual method, which is around 21.6 ms - 40.1 ms.

REFERENCES

- [1] A. F. Farizy, D. A. Asfani dan Soedibjo, "Desain Sistem Monitoring State of Charge Baterai pada Charging Station Mobil Listrik Berbasis Fuzzy Logic Dengan Mempertimbangkan Temperature," *Jurnal Teknik ITS*, vol. 5, no. 2, pp. 278-282, 2016.
- [2] U. Sutisna, Karyono dan S. Nurhadiyono, "Perancangan Saklar Pemindah Otomatis Pada Instalasi Genset Dengan Parameter Transisi Berupa Arus Berbasis Mikrokontroler ATMega16," *Techno*, vol. 16, no. 2, pp. 70-78, 2015.
- [3] Budiman, A. Taqwa dan RD.Kusumanto, "IoT Technology Monitoring, Controlling and Data Logging for ATS on grid Connected Solar-Wind Hybrid System," dalam *Journal of Physics: Conference Series*, Palembang, 2018.
- [4] F. D. Petruzella, *Electrical Motors and Control Systems*, New York: McGraw-Hill, 2010.
- [5] I. Lee dan K. Lee, "The Internet of Things (IoT) : Apliations, investment, and challenges for enterprises," *Business Horizons ScienceDirect*, vol. 58, no. 4, pp. 431-440, 2015.
- [6] Dealmarkaz.pk, "dealmarkaz," [Online]. Available: <https://dealmarkaz.pk/item/solar-atshybrid-system-digital-1224v-i17603>. [Diakses 29 Januari 2021].
- [7] Lazada, "Lazada - Electronicsstore," Electronicsstore, [Online]. Available: <https://www.lazada.co.id/products/automatic-ats-dual-power-transfer-switch-solar-charge-controller-for-solar-wind-system-dc-12v-24v-48v-ac-110v-220v-onoff-grid-i1214770973.html>. [Diakses 25 Januari 2021].
- [8] PT. Triguna Karya Nusantara, "Triguna," PT. Triguna Karya Nusantara, 2020. [Online]. Available: <https://www.triguna.co.id/product/panel-ats-amf-20-kva/>. [Diakses 11 10 2020].



Muhammad Abdillah was born in Pasuruan. He received Sarjana Teknik (equivalent to B.Eng.), and Magister Teknik (equivalent to M.Eng.) degrees from Department of Electrical Engineering, Institut Teknologi Sepuluh Nopember (ITS), Surabaya, Indonesia in 2009 and 2013, respectively. He obtained Dr Eng. degree from Graduate School of Engineering, Hiroshima University, Japan in 2017. He is currently working as a lecturer at the Department of Electrical Engineering, Universitas Pertamina, Jakarta, Indonesia. As author and co-author, he had published more than 100 scientific papers in different journals and conferences. He was a member of IEEJ, IAENG and IEEE. His research interests are power system operation and control, power system optimization, robust power system security, power system stability, intelligent control and system, and artificial intelligence (optimization, machine learning, deep

learning). He can be contacted at email:
m.abdillah@universitaspertamina.ac.id.



Tri Mutia received Sarjana Teknik (equivalent to B.Eng.) degrees from Department of Electrical Engineering, Universitas Pertamina. She has completed some projects related to electrical engineering fields such as renewable energy, control motor, programming, and Internet of Things (IoT). Currently, she is a digital forensic analyst at Yogyakarta District Attorney. She can be contacted at email: tri.mutia1997@gmail.com



Teguh Aryo Nugroho was born in Surabaya, Indonesia, on 1991. He received his B.Eng. and M.T. degrees in Electrical Engineering from Institut Teknologi Sepuluh Nopember Surabaya, in 2013 and 2015. His research focuses on electrical material insulation and high voltage engineering. Currently, he is working as lecturer at Electrical Engineering Department, Universitas Pertamina, Jakarta. He can be contacted at email: teguh.an@universitaspertamina.ac.id



Nita Indriani Pertiwi holds a Sarjana Teknik (equivalent to B.Eng) in 2013 and Magister Teknik (equivalent to M.Eng) in 2015 from Department of Electrical Engineering, Institut Teknologi Sepuluh Nopember (ITS). She is currently an Academician at Department of Electrical Engineering, Universitas Pertamina, Jakarta, Indonesia. Her research is mainly focused on Power System Operation, Electrical Machines, and Renewable Energy. She can be contacted at email: nitaindriani.p@universitaspertamina.ac.id.